

# Damper Louver Submittal

Sleeves for Dampers: 3000 & 3500

MODEL: Damper Sleeves

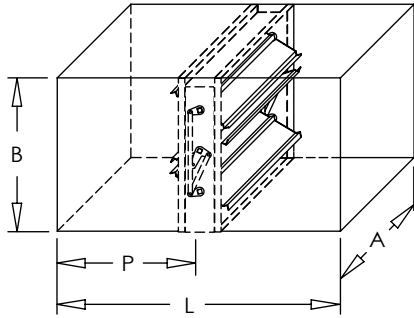

SLEEVE TYPE A

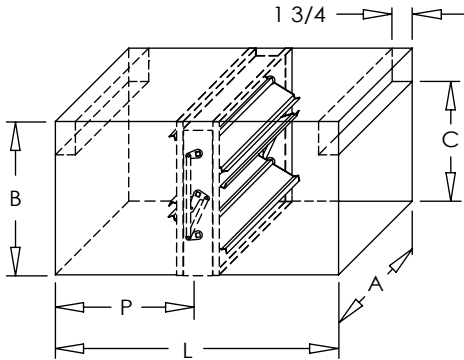

SLEEVE TYPE B

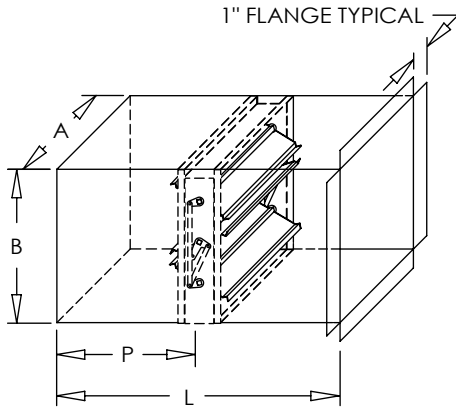

SLEEVE TYPE C

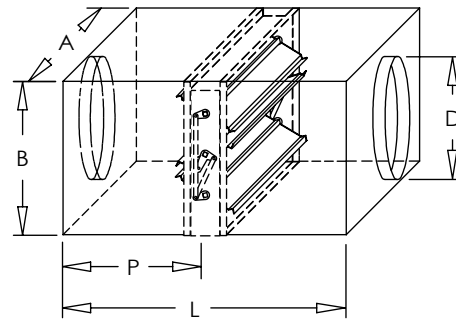

SLEEVE TYPE D

**Standard Features:**

- Sleeve Type A: Square or rectangular
- Standard sleeve length 18"
- 20 gauge galvanized steel
- Mill Finish

**Options:**

- Gauges: 14 through 22 ga.
- Aluminum sleeve (available only on 3000 series)
- Access door installed
- Retaining angles
- Available in sleeve lengths 6" through 20"
- Fractional O.D. sizes available

**Sleeve Styles:**

- Type B: Out-of-Airstream
- Type C: Square or rectangular with flange (Note: When ordered with 3500 series dampers must specify whether flange is on intake or exhaust side of damper)
- Type D: Square or rectangular with round collar (Note: Round collar must be 2" smaller than square sleeve dimension i.e. 10"x10"-8")

**Finishes:**

STANDARD COLORS

- Mill Finish

**Additional Information:**

**Submittal Notes**

Project / Location:	
Engineer:	
Architect:	
Contractor:	