

Damper Louver Submittal

Vertical Mount Pressure Relief Damper

MODEL: 3510 Series

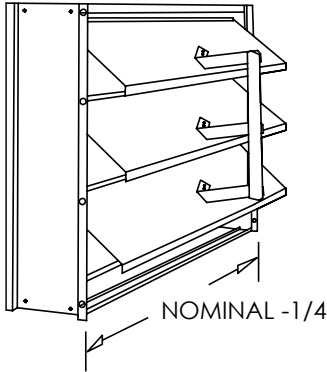

Standard Features:

- Designed to open in negative or positive pressures for intake or exhaust air
- All aluminum construction
- Blade to blade linkage
- Foam tape sealed blade edges to dampen noise
- Single blades on dampers with a height of 10" or less
- Blades run parallel to first dimension given
- 1/4" pivot pins in nylon bearings
- Minimum size 6"x6"
- Maximum size 24"x24"
- Mill Finish

Options:

Adjustable counter balance arms mounted to center of blades. Adjustable weights can be positioned along arm for various opening pressures. Available only on dampers with multiple blades.

Mounting flange

Sleeves (contact factory for details)

Fractional and exact O.D. dimensions

Finishes:

STANDARD COLORS

- Mill Finish

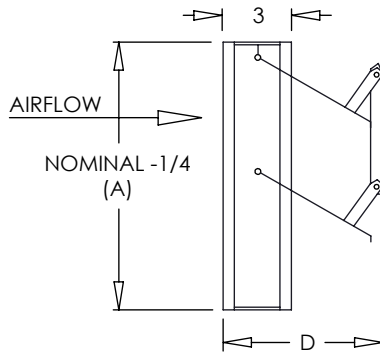

3510

3510	
DIMENSION (A)	OPEN DEPTH (D)
6"	6 1/4"
8"	8 1/4"
10"	10 1/4"
12"	7 7/8"
14"	8 3/4"
16"	7 1/2"
18"	8 5/8"
20"	7 3/4"
24"	8 1/8"

Additional Information:

Submittal Notes

Project / Location:	
Engineer:	
Architect:	
Contractor:	