

Fire Rated Submittal

Sleeves for Dampers: 2500 & 2600

MODEL: Fire Damper Sleeves Series

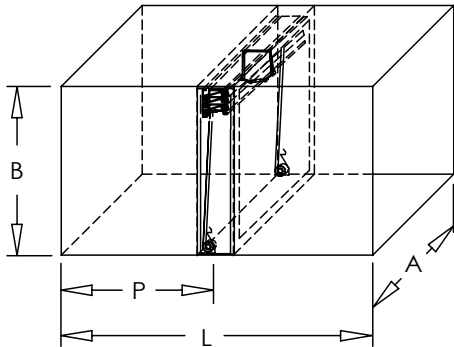

SLEEVE TYPE A

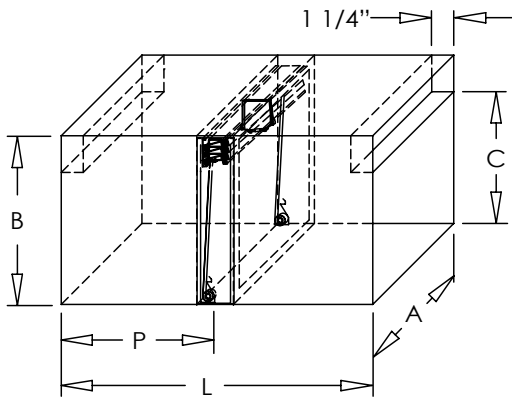

SLEEVE TYPE B

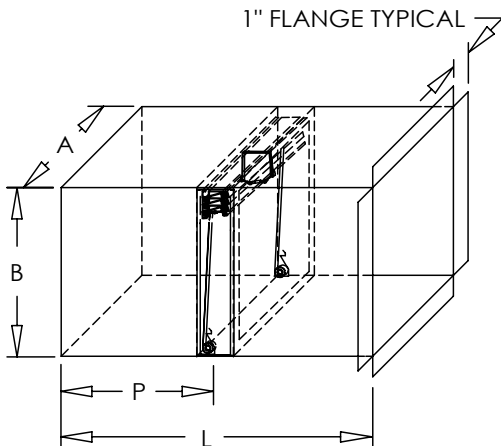

SLEEVE TYPE C

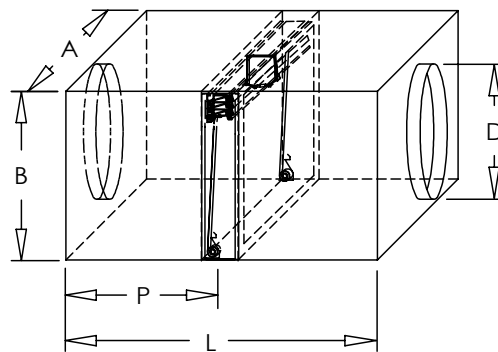

SLEEVE TYPE D

Standard Features:

- Sleeve Type A: Square or rectangular
- Standard sleeve length 18"
- 20 gauge galvanized steel
- Mill Finish

Options:

- Gauges: 14 through 22 ga.
- Access door installed
- Retaining angles
- Available in sleeve lengths 6" through 20"
- Fractional O.D. sizes available

Air Pattern Options:

- Type B: Out-of-Airstream
- Type C: Square or rectangular with flange
- Type D: Square or rectangular with round collar (Note: Round collar must be 2" smaller than square sleeve dimension i.e. 10"x10"-8")

Finishes:

STANDARD COLORS

- Mill Finish

Additional Information:

Submittal Notes

Project / Location:	
Engineer:	
Architect:	
Contractor:	